



APOGEE INSTRUMENTS UV-A SENSOR | SU-200-SS Series

Cost-effective measurement of UV radiation from 300 to 400 nm

Features

Overview

UV-A radiation is important in material sciences and has numerous photo-biological functions that are both harmful and beneficial. Apogee's new UV-A radiometers offer a low-cost option for continuously measuring UV-A radiation in outdoor environments, laboratory settings, and monitoring the filtering ability and stability of various materials.

Rugged, Self-cleaning Housing

Sensor features an anodized aluminum body with fully-potted electronics. The dome-shaped sensor head minimizes errors by shedding dust and water for a self-cleaning performance.

Calibration Traceability

Apogee UV series sensors are calibrated through side-by-side comparison to the mean of four transfer standard UV sensors under UV-enhanced T5 fluorescent tubes. The transfer standard UV sensors are calibrated through side-by-side comparison to an Apogee model PS-300 spectroradiometer under sunlight (clear sky conditions) in Logan, Utah. The PS-300 is calibrated with a quartz halogen lamp traceable to the National Institute of Standards and Technology (NIST).

Spectral Response

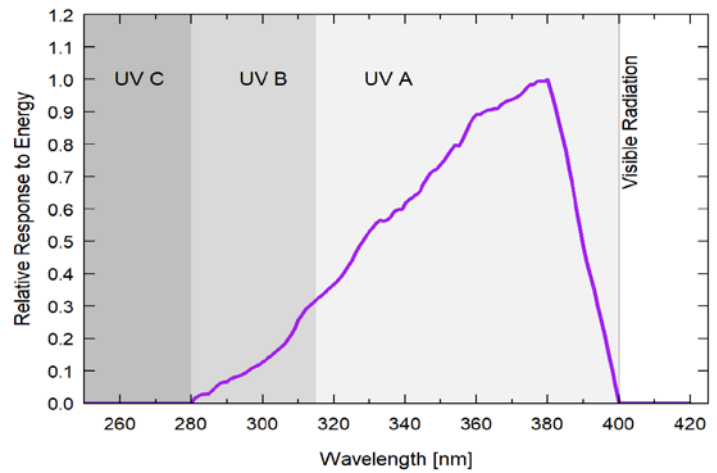

Spectral response estimate of Apogee SU-200 UV-A sensors. Spectral response was modeled from sensitivity of the photodetector and transmittance of the diffuser.

Cosine Response

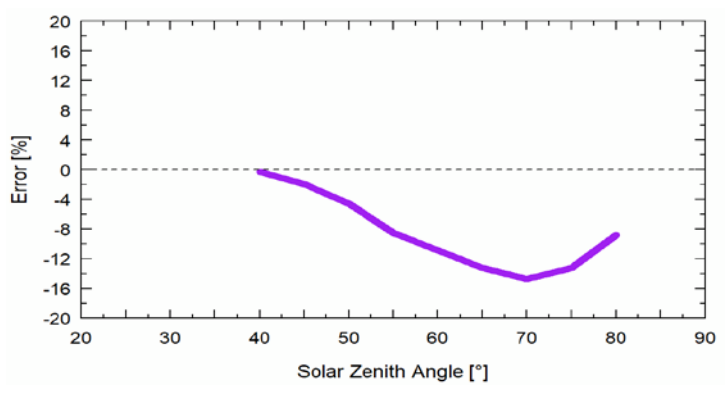

Mean cosine response of four Apogee UV-A sensors. Cosine response was calculated as the relative difference of UV-A sensors from the mean of replicate reference UV-A sensors deployed outdoors. These data are the average of the AM and PM response.

Dimensions

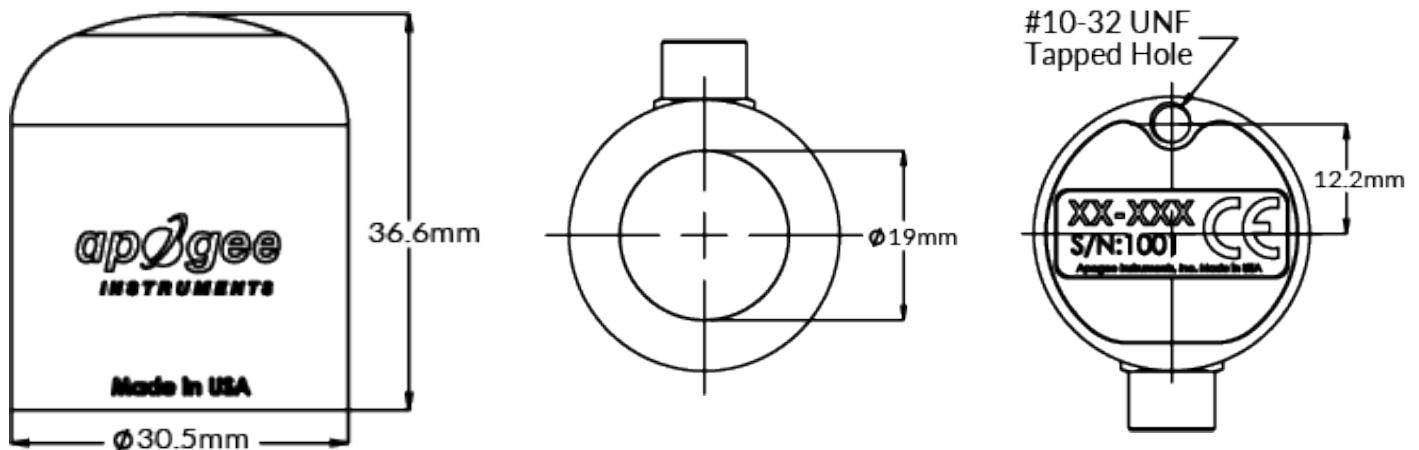

Product Specifications

	SU-200-SS	SU-202-SS	SU-205-SS
Power Supply	Self-powered	3.3 to 24 V DC	5.5 to 24 V DC
Output (sensitivity)	0.1 mV per $W m^{-2}$; 0.03 mV per $\mu mol m^{-2} s^{-1}$	25 mV per $W m^{-2}$; 8.33 mV per $\mu mol m^{-2} s^{-1}$	50 mV per $W m^{-2}$; 16.67 mV per $\mu mol m^{-2} s^{-1}$
Calibration Factor (reciprocal of sensitivity)	10 $W m^{-2}$ per mV; 30 $\mu mol m^{-2} s^{-1}$ per mV	0.04 $W m^{-2}$ per mV; 0.12 $\mu mol m^{-2} s^{-1}$ per mV	0.02 $W m^{-2}$ per mV; 0.06 $\mu mol m^{-2} s^{-1}$ per mV
Calibration Uncertainty	$\pm 10\%$		
Output Range	0 to 10 mV	0 to 2.5 V	0 to 5 V
Measurement Range	0 to 100 $W m^{-2}$		
Measurement Repeatability	Less than 0.5 %		
Long-term Drift	Less than 2 % per year		
Non-linearity	Less than 1 %		
Response Time	Less than 1 ms		
Field of View	180°		
Spectral Range	300 to 400 nm (wavelengths where response is greater than 10 % of maximum)		
Directional (Cosine) Response	$\pm 2\%$ at 45°; $\pm 5\%$ at 75° zenith angle		
Temperature Response	-0.1 % per C		
Operating Environment	-30 to 85 C; 0 to 100 % relative humidity		
Dimensions	30.5 mm diameter, 37 mm height		
Mass	140 g (with 5 m of lead wire)		
Cable	5 m of shielded, twisted-pair wire; TPR jacket (high water resistance, high UV stability, flexibility in cold conditions); pigtail lead wires; stainless steel (316), M8 connector located 25 cm from sensor head		
Warranty	4 years against defects in materials and workmanship		